

Ucho SC...

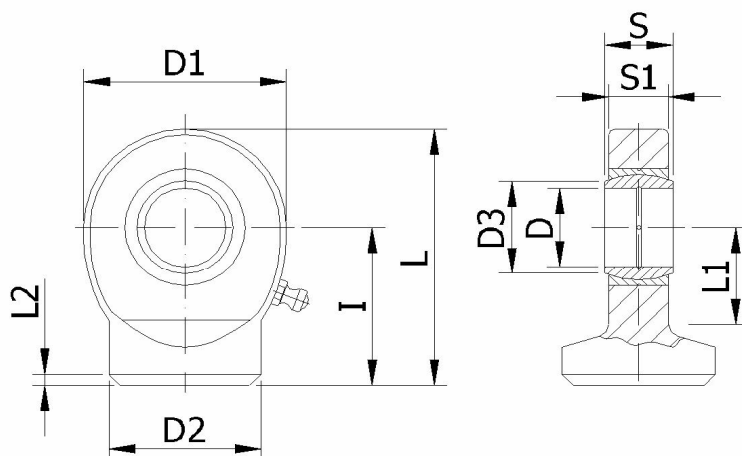
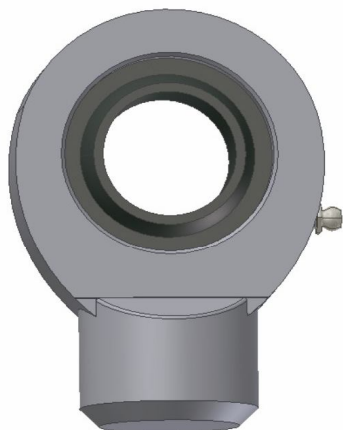

Material: St52.3

Oznaczenie	D	S	I	D1	D2	D4	D3	S1	L	L1	L2	Obciążenie	
												Stat.	Dyn.
												(kN)	(kN)
HU-S10C	10	9	24	29	15	3	13,2	6,5	38,5	14	2	15,6	8,15
HU-S12C	12	10	27	36	17,5	3	15	8	44	18	2	21,6	10,8
HU-S15C	15	12	31	40	21	4	18,4	10	51	20	2,5	32	17
HU-S17C	17	14	35	47	24	4	20,7	11	58	23	3	40	21,2
HU-S20C	20	16	38	53	27,5	4	24,1	13	64,5	27,5	3	54	30
HU-S25C	25	20	45	64	33,5	4	29,3	17	77	33	4	72	48
HU-S30C	30	22	51	73	40	4	34,2	19	87,5	37,5	4	95	62
HU-S35C	35	25	61	82	47	4	39,7	21	102	43	4	125	80
HU-S40C	40	28	69	92	52	4	45	23	115	48	5	156	100
HU-S45C	45	32	77	102	58	6	50,7	27	128	52	5	208	127
HU-S50C	50	35	88	112	62	6	56	30	144	59	6	250	156
HU-S60C	60	44	100	137	70	6	66,8	38	167,5	72,5	8	390	245
HU-S70C	70	49	115	161	80	6	77,8	42	195	86	10	510	315
HU-S80C	80	55	141	180	95	6	89,4	47	231	98	10	620	400